

| PART NO. | MAST DIAMETER | WEIGHT |
|-----------|---------------|---------|
| B46-237X3 | 2.37"OD | 86 lbs. |
| B46-288X3 | 2.88"OD | 87 lbs. |

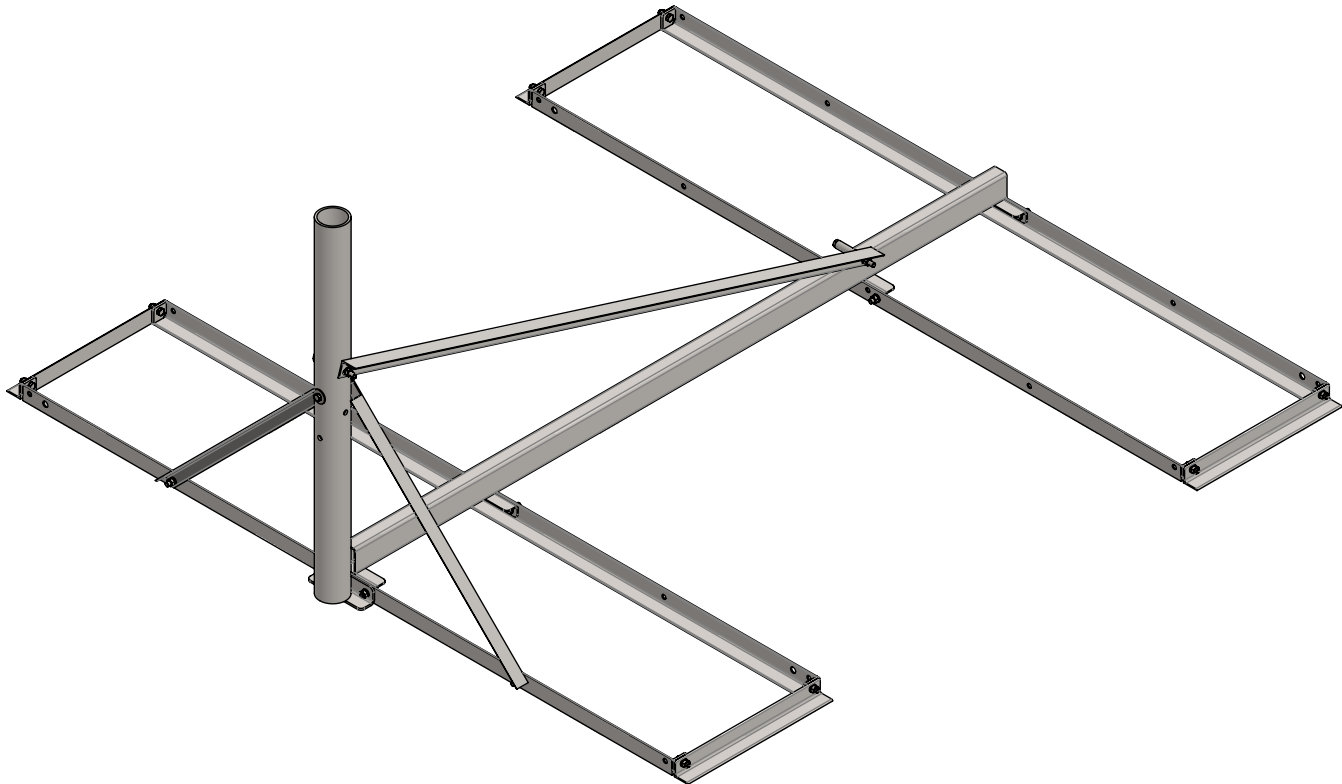

PROPRIETARY AND CONFIDENTIAL
 THE INFORMATION CONTAINED IN THIS DRAWING IS THE SOLE PROPERTY OF BAIRD SUPPORTING SYSTEMS. ANY REPRODUCTION IN PART OR AS A WHOLE WITHOUT THE WRITTEN PERMISSION OF BAIRD SUPPORTING SYSTEMS IS PROHIBITED.



UNLESS OTHERWISE SPECIFIED:
 DIMENSIONS ARE IN INCHES
 TOLERANCES:
 FRACTIONAL ±
 ANGULAR: MACH ± BEND ±
 TWO PLACE DECIMAL ±
 THREE PLACE DECIMAL ±

DO NOT SCALE DRAWING

BAIRD MOUNTING SYSTEMS

WATERLOO, IA 50703
 PHONE: 319-233-3561
 SALES@BAIRD MOUNTS.COM

TITLE:
 B4-6X6 MOUNT WITH 3' MAST

| | |
|--------------------------|------------------|
| DRAWN BY JK | DATE 04/06/18 |
| MATERIAL STEEL | FINISH HDG |
| DWG. PURPOSE CUSTOMER | SHEET 1 OF 2 |
| SCALE - | |
| PART. NO. SEE TABLE | |
| DWG. NO. B46-(000)X3 | |

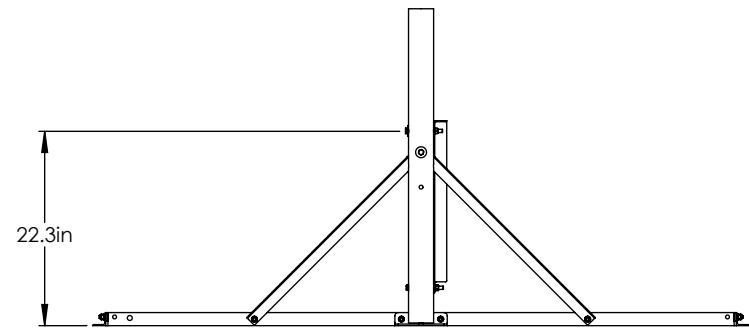
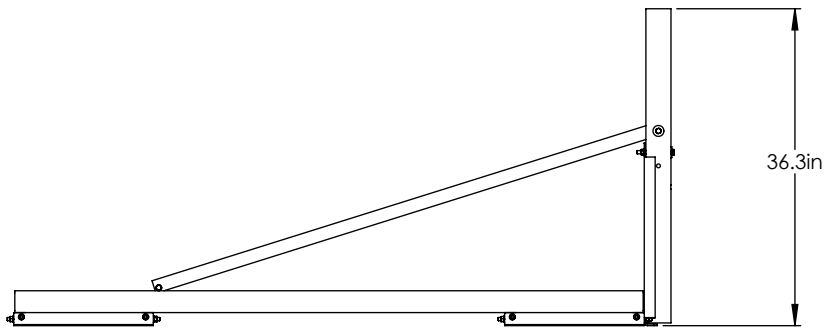
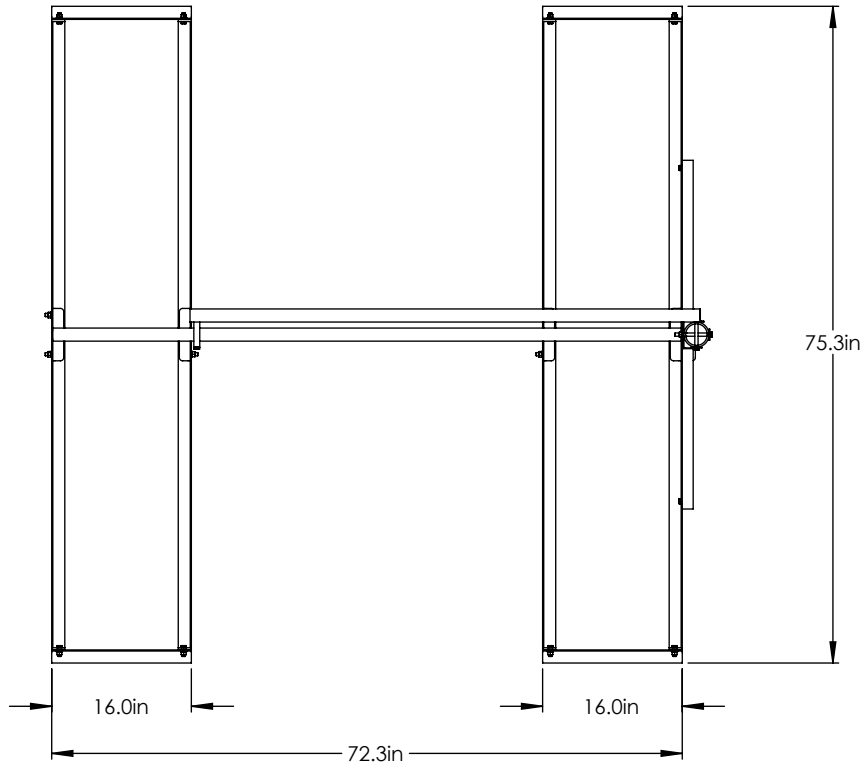

PROPRIETARY AND CONFIDENTIAL
 THE INFORMATION CONTAINED IN THIS DRAWING IS THE SOLE PROPERTY OF BAIRD SUPPORTING SYSTEMS. ANY REPRODUCTION IN PART OR AS A WHOLE WITHOUT THE WRITTEN PERMISSION OF BAIRD SUPPORTING SYSTEMS IS PROHIBITED.



WWW.BAIRD MOUNTS.COM

UNLESS OTHERWISE SPECIFIED:
 DIMENSIONS ARE IN INCHES
 TOLERANCES:
 FRACTIONAL ±
 ANGULAR: MACH ± BEND ±
 TWO PLACE DECIMAL ±
 THREE PLACE DECIMAL ±

DO NOT SCALE DRAWING

BAIRD MOUNTING SYSTEMS

WATERLOO, IA 50703
 PHONE: 319-233-3561
 SALES@BAIRDMOUNTS.COM

TITLE:
 B4-6X6 MOUNT WITH 3' MAST

| | | |
|--------------------------|------------------|---------------|
| DRAWN BY JK | DATE 04/06/18 | |
| MATERIAL STEEL | FINISH HDG | |
| DWG. PURPOSE CUSTOMER | SHEET 2OF2 | SCALE 1:25 |

PART. NO.
 SEE TABLE-SHEET 1

DWG. NO.
 B46-(000)X3

| PART NO. | MAST DIAMETER | WEIGHT |
|--------------|---------------|---------|
| B46DRB-237X3 | 2.37"OD | 93 lbs. |
| B46DRB-288X3 | 2.88"OD | 94 lbs. |

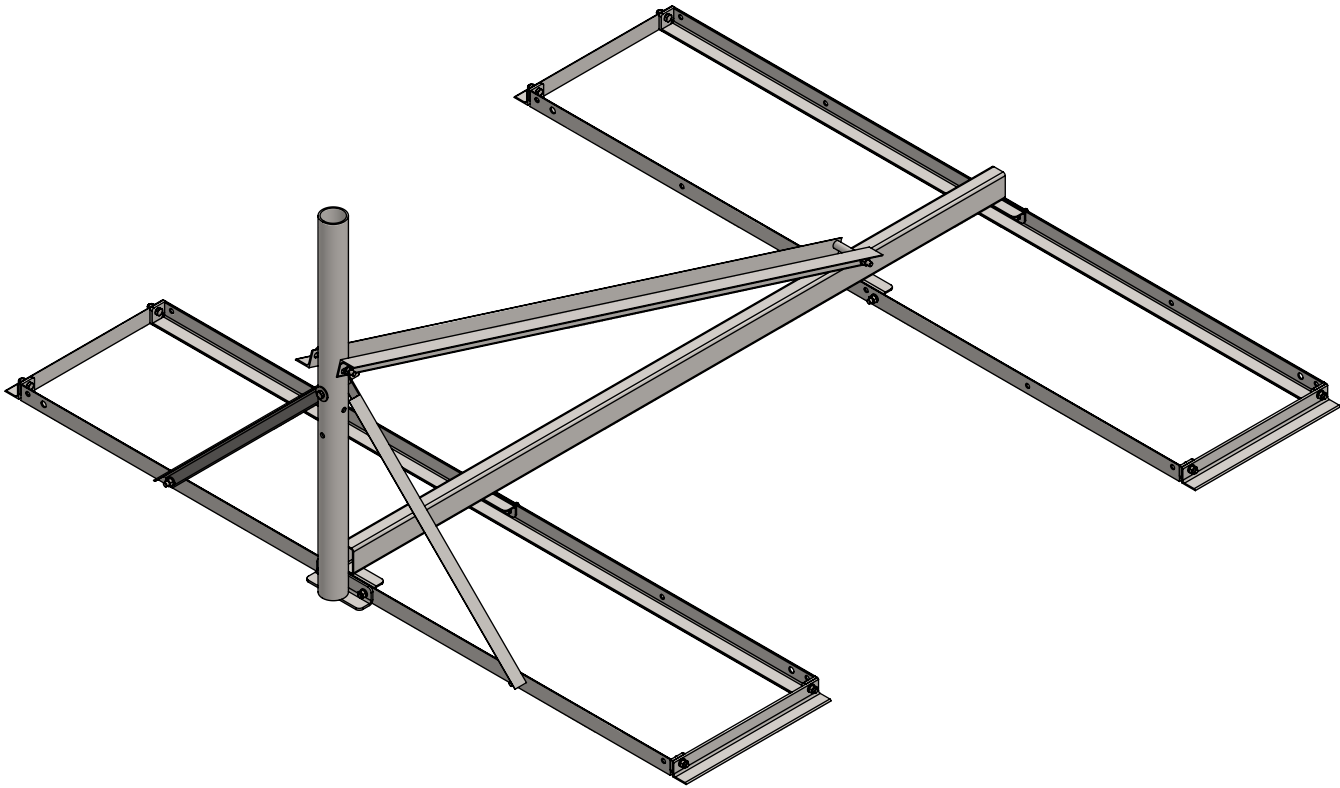

PROPRIETARY AND CONFIDENTIAL
 THE INFORMATION CONTAINED IN THIS DRAWING IS THE SOLE PROPERTY OF BAIRD SUPPORTING SYSTEMS. ANY REPRODUCTION IN PART OR AS A WHOLE WITHOUT THE WRITTEN PERMISSION OF BAIRD SUPPORTING SYSTEMS IS PROHIBITED.



WWW.BAIRD MOUNTS.COM

UNLESS OTHERWISE SPECIFIED:
 DIMENSIONS ARE IN INCHES
 TOLERANCES:
 FRACTIONAL ±
 ANGULAR: MACH ± BEND ±
 TWO PLACE DECIMAL ±
 THREE PLACE DECIMAL ±

DO NOT SCALE DRAWING

BAIRD MOUNTING SYSTEMS

WATERLOO, IA 50703
 PHONE: 319-233-3561
 SALES@BAIRD MOUNTS.COM

TITLE:
 B4-6X6DRB MOUNT WITH 3' MAST

| | |
|--------------------------|------------------|
| DRAWN BY JK | DATE 04/22/19 |
| MATERIAL STEEL | FINISH HDG |
| DWG. PURPOSE CUSTOMER | SHEET 1 OF 2 |
| | SCALE - |

PART. NO.
 SEE TABLE
 DWG. NO.
 B46DRB-(000)X3

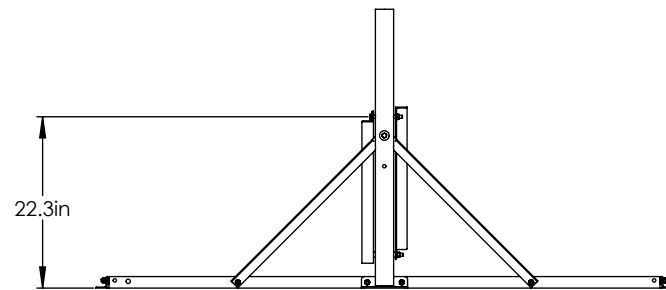
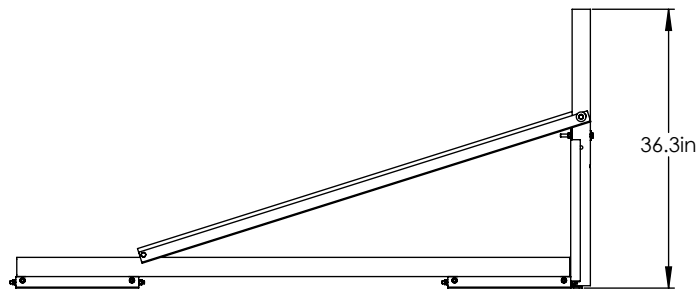
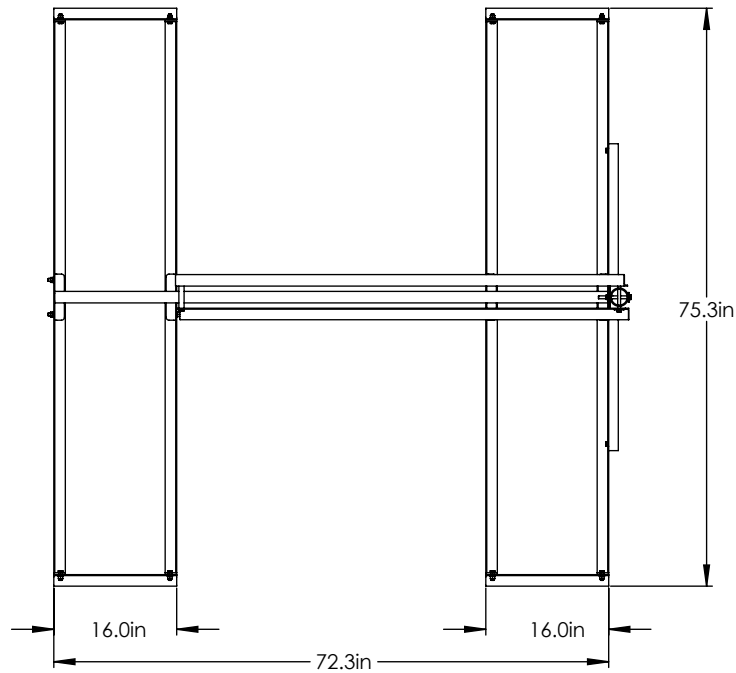

PROPRIETARY AND CONFIDENTIAL
 THE INFORMATION CONTAINED IN THIS DRAWING IS THE SOLE PROPERTY OF BAIRD SUPPORTING SYSTEMS. ANY REPRODUCTION IN PART OR AS A WHOLE WITHOUT THE WRITTEN PERMISSION OF BAIRD SUPPORTING SYSTEMS IS PROHIBITED.



WWW.BAIRD MOUNTS.COM

UNLESS OTHERWISE SPECIFIED:
 DIMENSIONS ARE IN INCHES
 TOLERANCES:
 FRACTIONAL ±
 ANGULAR: MACH ± BEND ±
 TWO PLACE DECIMAL ±
 THREE PLACE DECIMAL ±

DO NOT SCALE DRAWING

BAIRD MOUNTING SYSTEMS

WATERLOO, IA 50703
 PHONE: 319-233-3561
 SALES@BAIRD MOUNTS.COM

TITLE:
 B4-6X6DRB MOUNT WITH 3' MAST

| | |
|--------------------------|------------------|
| DRAWN BY JK | DATE 04/22/19 |
| MATERIAL STEEL | FINISH HDG |
| DWG. PURPOSE CUSTOMER | SHEET 2OF2 |
| | SCALE - |

PART. NO.
 SEE TABLE-SHEET 1
 DWG. NO.
 B46DRB-(000)X3

| PART NO. | MAST DIAMETER | WEIGHT |
|--------------|---------------|----------|
| B46DRB-237X5 | 2.37"OD | 101 lbs. |
| B46DRB-288X5 | 2.88"OD | 106 lbs. |

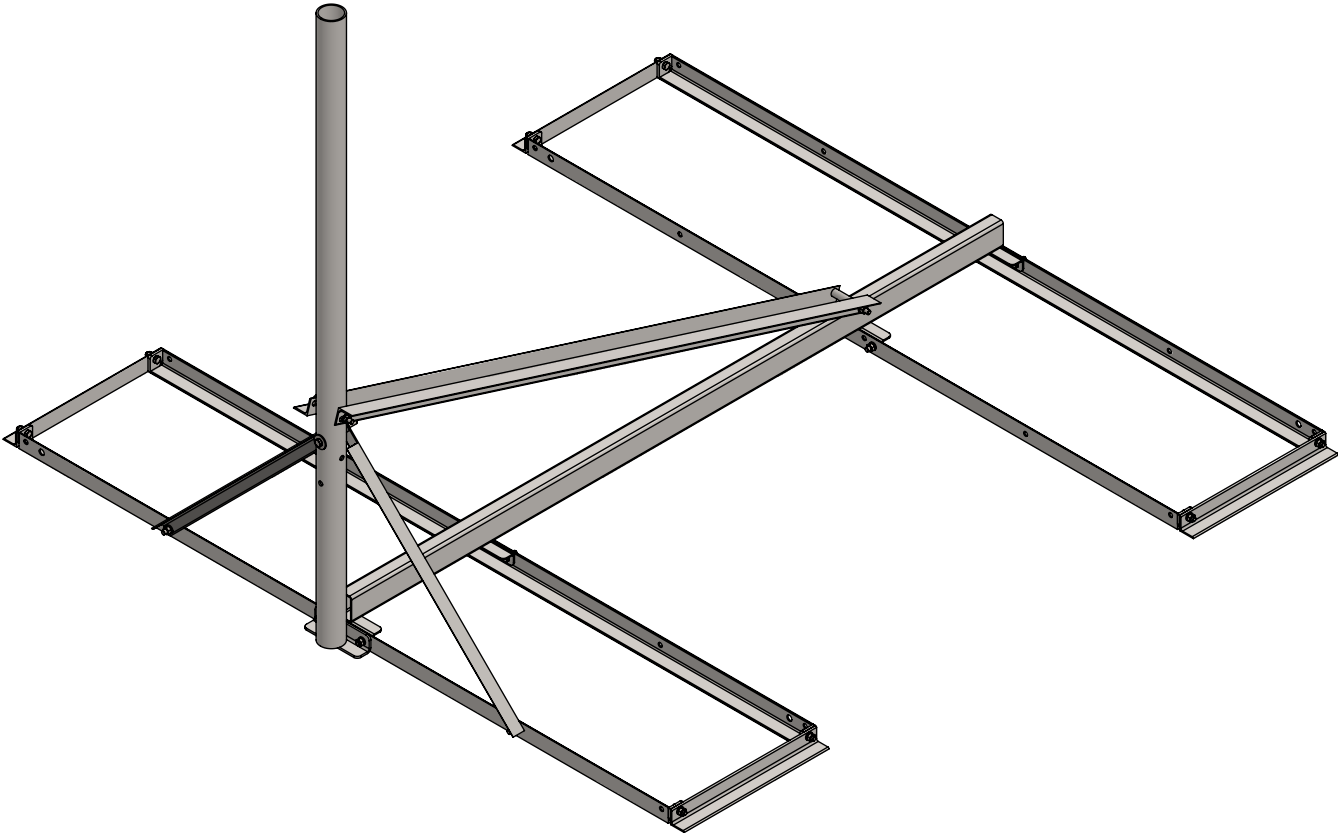

PROPRIETARY AND CONFIDENTIAL
 THE INFORMATION CONTAINED IN THIS DRAWING IS THE SOLE PROPERTY OF BAIRD SUPPORTING SYSTEMS. ANY REPRODUCTION IN PART OR AS A WHOLE WITHOUT THE WRITTEN PERMISSION OF BAIRD SUPPORTING SYSTEMS IS PROHIBITED.



WWW.BAIRD MOUNTS.COM

UNLESS OTHERWISE SPECIFIED:
 DIMENSIONS ARE IN INCHES
 TOLERANCES:
 FRACTIONAL ±
 ANGULAR: MACH ± BEND ±
 TWO PLACE DECIMAL ±
 THREE PLACE DECIMAL ±

DO NOT SCALE DRAWING

BAIRD MOUNTING SYSTEMS

WATERLOO, IA 50703
 PHONE: 319-233-3561
 SALES@BAIRD MOUNTS.COM

DESCRIPTION:
 B4-6X6DRB MOUNT WITH 5' MAST

| | | |
|----------------------------|------------------|------------|
| DRAWN BY JK | DATE 04/06/18 | |
| MATERIAL STEEL | FINISH HDG | |
| DWG. PURPOSE CUSTOMER | SHEET 1 OF 2 | SCALE - |
| PART. NO. SEE TABLE | | |
| DWG. NO. B46DRB-(000)X5 | | |

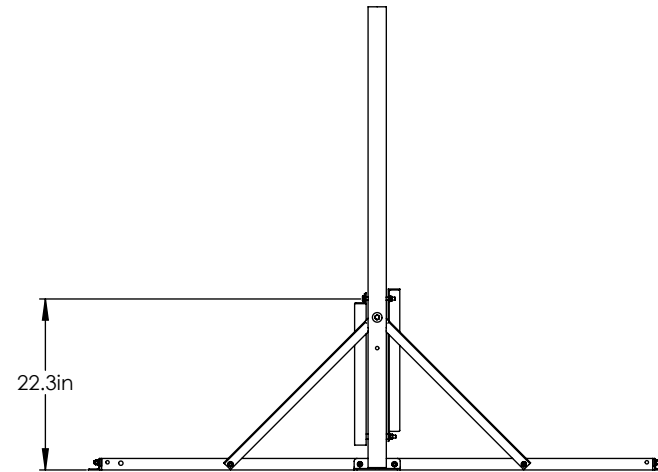
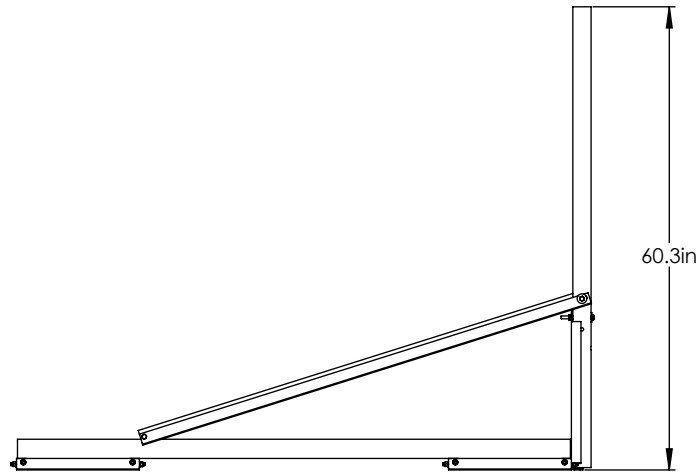
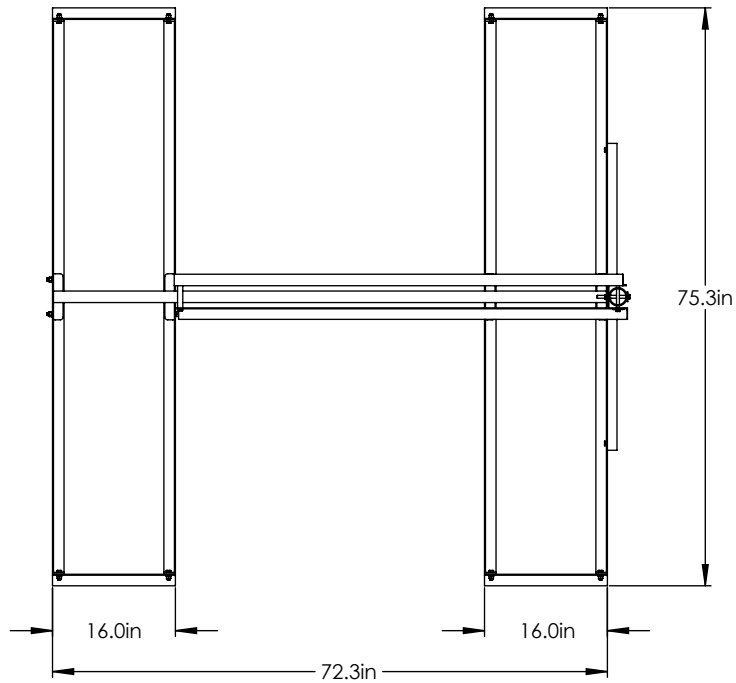

PROPRIETARY AND CONFIDENTIAL
 THE INFORMATION CONTAINED IN THIS DRAWING IS THE SOLE PROPERTY OF BAIRD SUPPORTING SYSTEMS. ANY REPRODUCTION IN PART OR AS A WHOLE WITHOUT THE WRITTEN PERMISSION OF BAIRD SUPPORTING SYSTEMS IS PROHIBITED.



WWW.BAIRD MOUNTS.COM

UNLESS OTHERWISE SPECIFIED:
 DIMENSIONS ARE IN INCHES
 TOLERANCES:
 FRACTIONAL ±
 ANGULAR: MACH ± BEND ±
 TWO PLACE DECIMAL ±
 THREE PLACE DECIMAL ±

DO NOT SCALE DRAWING

BAIRD MOUNTING SYSTEMS

WATERLOO, IA 50703
 PHONE: 319-233-3561
 SALES@BAIRDMOUNTS.COM

TITLE:
 B4-6X6DRB MOUNT WITH 5' MAST

| | |
|--------------------------|------------------|
| DRAWN BY JK | DATE 04/06/18 |
| MATERIAL STEEL | FINISH HDG |
| DWG. PURPOSE CUSTOMER | SHEET 2OF2 |
| | SCALE 1:25 |

PART. NO.
 SEE TABLE-SHEET 1

DWG. NO.
 B46DRB-(000)X5

| PART NO. | MAST DIAMETER | WEIGHT |
|--------------|---------------|----------|
| B46DRB-237X8 | 2.37"OD | 112 lbs. |
| B46DRB-288X8 | 2.88"OD | 124 lbs. |

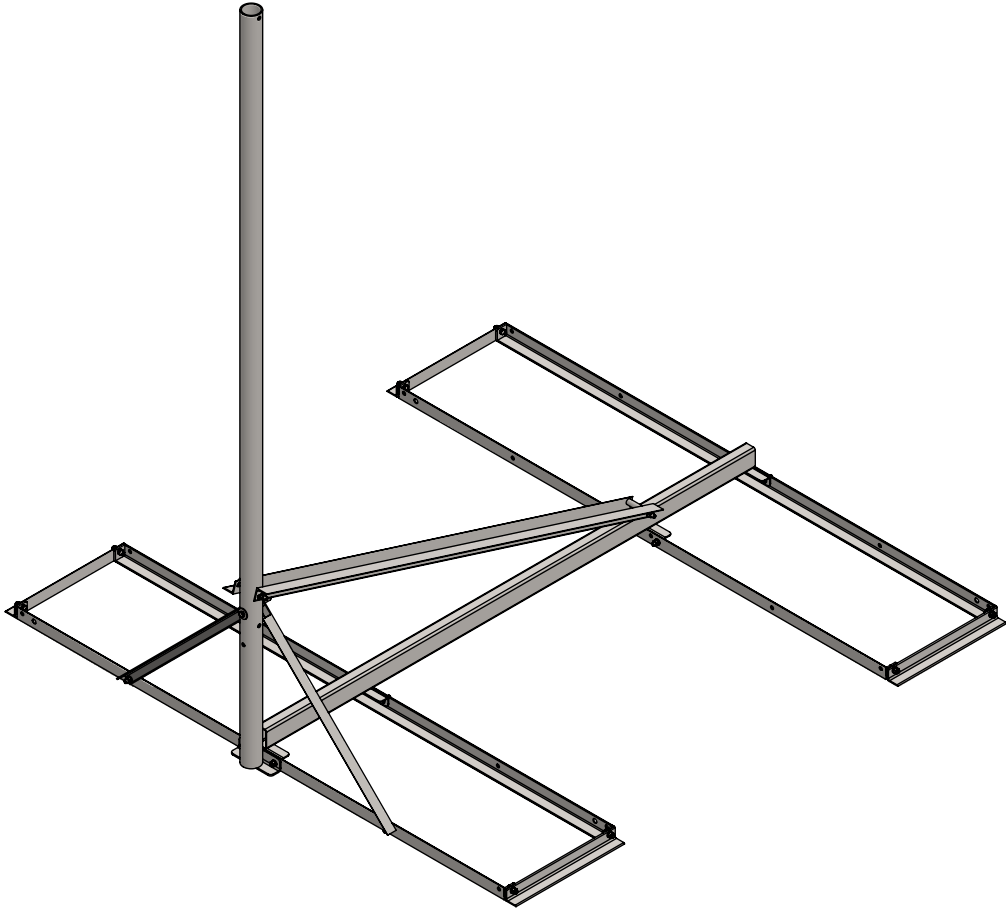

PROPRIETARY AND CONFIDENTIAL
 THE INFORMATION CONTAINED IN THIS DRAWING IS THE SOLE PROPERTY OF BAIRD SUPPORTING SYSTEMS. ANY REPRODUCTION IN PART OR AS A WHOLE WITHOUT THE WRITTEN PERMISSION OF BAIRD SUPPORTING SYSTEMS IS PROHIBITED.



WWW.BAIRD MOUNTS.COM

UNLESS OTHERWISE SPECIFIED:
 DIMENSIONS ARE IN INCHES
 TOLERANCES:
 FRACTIONAL ±
 ANGULAR: MACH ± BEND ±
 TWO PLACE DECIMAL ±
 THREE PLACE DECIMAL ±

DO NOT SCALE DRAWING

BAIRD MOUNTING SYSTEMS

WATERLOO, IA 50703
 PHONE: 319-233-3561
 SALES@BAIRD MOUNTS.COM

DESCRIPTION:
 B4-6X6DRB MOUNT WITH 8' MAST

| | | |
|----------------------------|------------------|------------|
| DRAWN BY JK | DATE 04/06/18 | |
| MATERIAL STEEL | FINISH HDG | |
| DWG. PURPOSE CUSTOMER | SHEET 1 OF 2 | SCALE - |
| PART. NO. SEE TABLE | | |
| DWG. NO. B46DRB-(000)X8 | | |

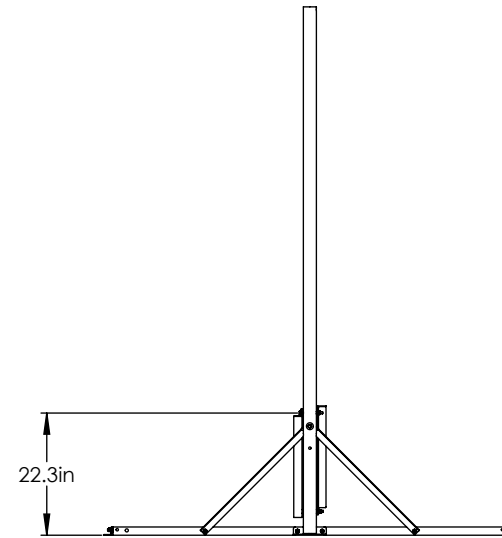
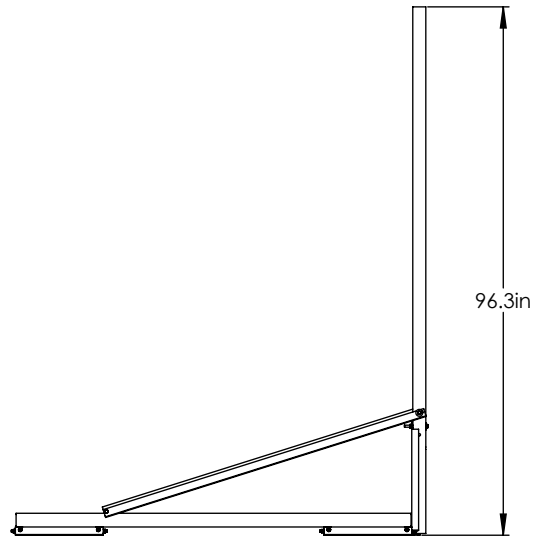
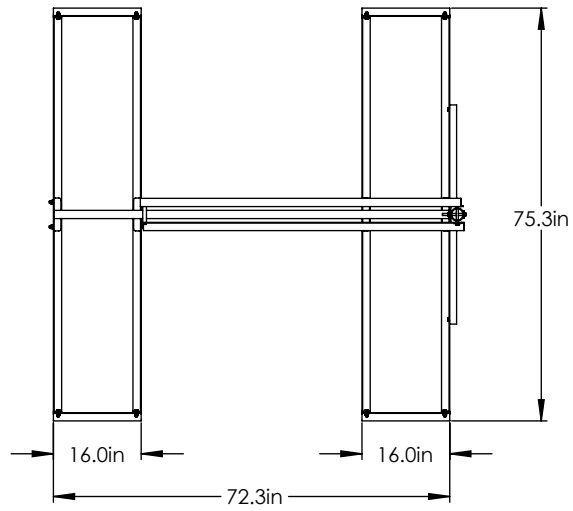

PROPRIETARY AND CONFIDENTIAL
 THE INFORMATION CONTAINED IN THIS DRAWING IS THE SOLE PROPERTY OF BAIRD SUPPORTING SYSTEMS. ANY REPRODUCTION IN PART OR AS A WHOLE WITHOUT THE WRITTEN PERMISSION OF BAIRD SUPPORTING SYSTEMS IS PROHIBITED.



WWW.BAIRDMOUNTS.COM

UNLESS OTHERWISE SPECIFIED:
 DIMENSIONS ARE IN INCHES
 TOLERANCES:
 FRACTIONAL ±
 ANGULAR: MACH ± BEND ±
 TWO PLACE DECIMAL ±
 THREE PLACE DECIMAL ±

DO NOT SCALE DRAWING

BAIRD MOUNTING SYSTEMS

WATERLOO, IA 50703
 PHONE: 319-233-3561
 SALES@BAIRDMOUNTS.COM

TITLE:
 B4-6X6DRB MOUNT WITH 8' MAST

| | | |
|--------------------------|------------------|------------|
| DRAWN BY JK | DATE 04/06/18 | |
| MATERIAL STEEL | FINISH HDG | |
| DWG. PURPOSE CUSTOMER | SHEET 2OF2 | SCALE - |

PART. NO.
 SEE TABLE-SHEET 1
 DWG. NO.
 B46DRB-(000)X8

| PART NO. | MAST DIAMETER | WEIGHT |
|---------------|---------------|----------|
| B46DRB-237X10 | 2.37"OD | 120 lbs. |
| B46DRB-288X10 | 2.88"OD | 136lbs. |



PROPRIETARY AND CONFIDENTIAL
 THE INFORMATION CONTAINED IN THIS DRAWING IS THE SOLE PROPERTY OF BAIRD SUPPORTING SYSTEMS. ANY REPRODUCTION IN PART OR AS A WHOLE WITHOUT THE WRITTEN PERMISSION OF BAIRD SUPPORTING SYSTEMS IS PROHIBITED.



WWW.BAIRD MOUNTS.COM

UNLESS OTHERWISE SPECIFIED:
 DIMENSIONS ARE IN INCHES
 TOLERANCES:
 FRACTIONAL ±
 ANGULAR: MACH ± BEND ±
 TWO PLACE DECIMAL ±
 THREE PLACE DECIMAL ±

DO NOT SCALE DRAWING

BAIRD MOUNTING SYSTEMS

WATERLOO, IA 50703
 PHONE: 319-233-3561
 SALES@BAIRD MOUNTS.COM

DESCRIPTION:
 B4-6X6DRB MOUNT WITH 10' MAST

| | | |
|-----------------------------|------------------|------------|
| DRAWN BY JK | DATE 04/06/18 | |
| MATERIAL STEEL | FINISH HDG | |
| DWG. PURPOSE CUSTOMER | SHEET 1OF2 | SCALE - |
| PART. NO. SEE TABLE | | |
| DWG. NO. B46DRB-(000)X10 | | |

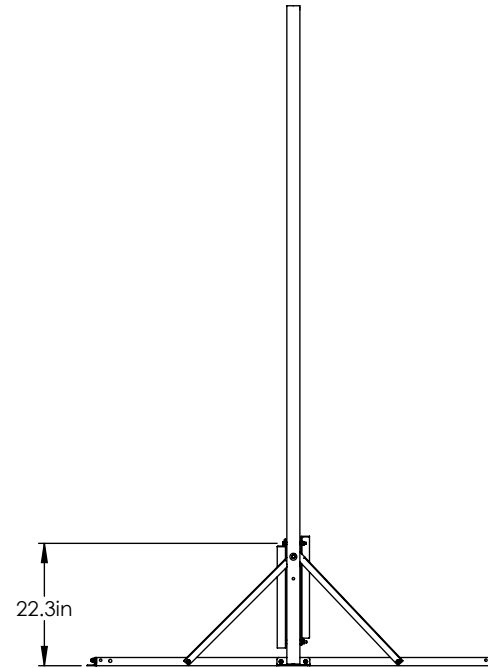
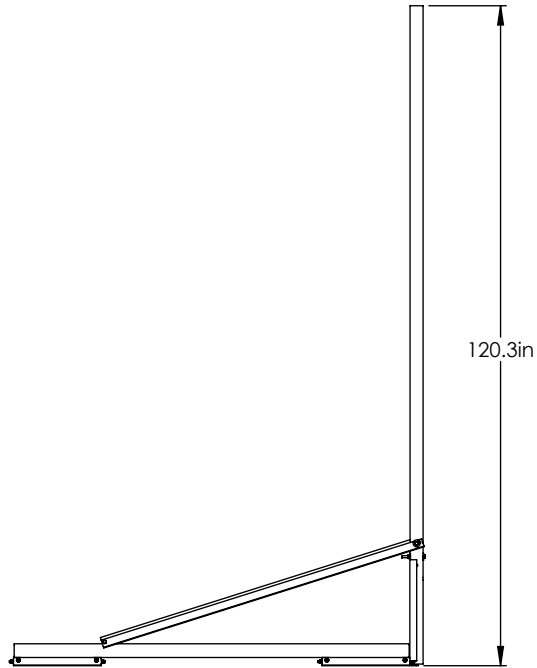
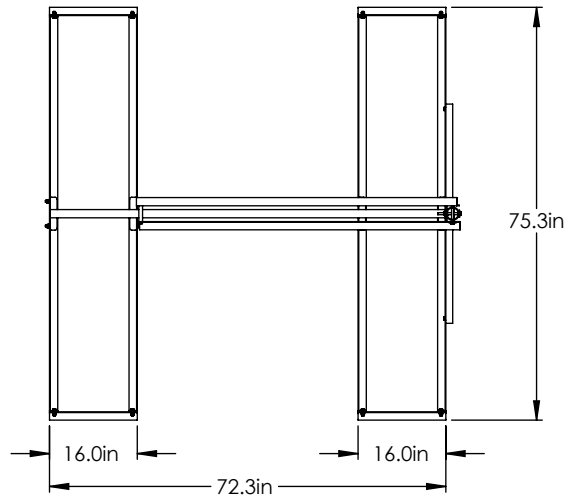

PROPRIETARY AND CONFIDENTIAL
 THE INFORMATION CONTAINED IN THIS DRAWING IS THE SOLE PROPERTY OF BAIRD SUPPORTING SYSTEMS. ANY REPRODUCTION IN PART OR AS A WHOLE WITHOUT THE WRITTEN PERMISSION OF BAIRD SUPPORTING SYSTEMS IS PROHIBITED.



WWW.BAIRD MOUNTS.COM

UNLESS OTHERWISE SPECIFIED:
 DIMENSIONS ARE IN INCHES
 TOLERANCES:
 FRACTIONAL ±
 ANGULAR: MACH ± BEND ±
 TWO PLACE DECIMAL ±
 THREE PLACE DECIMAL ±

DO NOT SCALE DRAWING

BAIRD MOUNTING SYSTEMS

WATERLOO, IA 50703
 PHONE: 319-233-3561
 SALES@BAIRD MOUNTS.COM

TITLE:
 B4-6X6DRB MOUNT WITH 10' MAST

| | |
|--------------------------|------------------|
| DRAWN BY JK | DATE 04/06/18 |
| MATERIAL STEEL | FINISH HDG |
| DWG. PURPOSE CUSTOMER | SHEET 2OF2 |
| | SCALE - |

PART. NO.
 SEE TABLE-SHEET 1

DWG. NO.
 B46DRB-(000)X10